

Helicopters

In Search and Rescue

Basic Level



Charley Shimanski
Mountain Rescue Association
www.mra.org

Helicopters in Search and Rescue Basic Level

Charley Shimanski



Mountain Rescue Association

www.mra.org

© 2012, Charley Shimanski/Mountain Rescue Association – All rights reserved

COVER PHOTO: Wasatch Backcountry Rescue, a volunteer avalanche rescue group composed of professional ski area personnel in northern Utah, trains for loading their avalanche rescue dogs into Wasatch Powderbird Guides' helicopter. Wasatch Powderbird Guides is a helicopter skiing operation and they are usually available to fly rescuers to the scene of an accident. Photo courtesy Bruce Tremper.

Table of Contents

Objective	1
Introduction.....	1
Part 1 – Helicopter Basics	3
Use of Helicopters.....	3
Helicopter Limitations	4
Classifications of Helicopters.....	5
Part 2 – What Makes a Helicopter Fly (Besides Money)	8
Aerodynamics	8
Helicopter Design.....	8
Helicopter Controls	8
Types of Landing Gear.....	10
Part 3 – Principles of Flight	11
Ground Effect.....	11
Translational Lift	11
Normal Takeoff.....	12
Maximum Performance Takeoff	12
Autorotation.....	12
Part 4 – Helicopter Management and Safety Precautions	14
Landing Zones (“LZs”).....	14
Air-to-Ground and Ground-to-Air Radio Traffic	16
Landings and Takeoffs	17
Loading and Unloading.....	21
Part 5 – Search and Rescue Helicopter Operations.....	25
Rescuers aboard Helicopters.....	25
Dogs aboard Helicopters:.....	25
Searching From Helicopters.....	26
Extrication of Subjects by Helicopter	27
Extricating Uninjured Search Subjects.....	27
Emergency Procedures.....	28
Conclusion	29
Acknowledgements.....	29



Objective

The Mountain Rescue Association (MRA), a volunteer organization dedicated to saving lives through rescue and mountain safety education, has developed this program to assist search and rescue (SAR) organizations in their helicopter operations.

This material is designed for search and rescue professionals that work occasionally with helicopters in their search and/or rescue operations.

At the conclusion of this program, students should be able to:

- Understand the basic functions and operation of helicopters
- Identify several key elements that contribute to effective media relations; and,
- Identify several means of communicating with the media, and the advantages of each.

About the Author

Charley Shimanski is President and Education Director for the Mountain Rescue Association, a national organization of rescue mountaineers. A 20-year veteran of Colorado's *Alpine Rescue Team*, Charley has participated as a field member and Incident Commander for hundreds of rescues among Colorado's highest peaks.

The author of the Mountain Rescue Association's *Helicopters in Mountain Rescue Operations* manuals and co-author of the *Avalanche Rescue Operations* manual, Charley has consulted rescue mountaineers, mountain guides, and climbers throughout the world, from Israel to China, from Kilimanjaro to Aconcagua. Charley is a frequent speaker at meetings of the International Technical Rescue Symposium, The National Association of Search and Rescue, the Wilderness Medical Society, and the Mountain Rescue Association.

Dedication

This program is dedicated to Peter Peelgrane, Chief Helicopter Pilot, KUSA-TV, Denver. As a pilot, Peter demonstrated unparalleled concern for mankind, clear focus on safety and uncanny eyes of an eagle. As a friend, he displayed ardent determination to overcome hardship and a questionable sense of humor. For all these things, Peter, we miss you.

Introduction

Nothing has changed search and rescue (SAR) work more dramatically than the development and refinement of helicopters, especially those with turbine engines. Helicopters have become a vital function in search and rescue operations. The military, local television stations and private services provide air support, in the form of helicopters, often with a moment's notice.

Because more and more local areas are gaining access to helicopters for use in search, rescue and emergency response, it is essential that everyone who may have to work around these aircraft have a thorough orientation to helicopter safety. As a search and reconnaissance platform coupled with rescue and extrication capabilities, the helicopter is unparalleled in its versatility for emergency and disaster response.

Helicopters are commonly used by search and rescue teams. In a 1988 Colorado search for a missing hiker, Alpine Rescue Team utilized seven helicopters at different times: two Army Chinooks, three news helicopters and two charter helicopters. These airborne resources were utilized primarily for transport of searchers (by Chinook) and spotting for the victim (by news helicopter). In addition, they were vital in the life-saving rescue efforts of the survivor of a Civil Air Patrol plane crash when NBC affiliate KCNC-TV pilot Mike Silva found the crash site and guided field teams as well as the Army Chinook carrying the bash team to the site. Silva also assisted with the extrication from the top of Pendleton Mountain of several searchers suffering from Acute Mountain Sickness. The charter helicopter was used to fly infrared scanning equipment in the early morning hours and CBS affiliate KMGH pilots Peter Peelgrane and Lyle Gurley as well as KCNC's Silva would fly countless days on search patterns.

Despite the fact that helicopters are uniquely valuable, they can be extremely dangerous. With rotors turning at over 150 M.P.H., the hazard to searchers is very real. In addition, the threat of a helicopter crash poses another danger.



Despite the fact that helicopters are uniquely valuable, they can be extremely dangerous. Photo: Office of Aircraft Services (OAS)

In the United States, there have been several accidents involving rescue helicopters;

- In 1995 a Honolulu Fire Department helicopter crashed while inserting two rescuers during a search for a missing hiker. The pilot and two rescuers were killed.
- In 1997, a contract Bell 205 helicopter crashed with eight rescuers on board on the North side of Mt. Baldy in Olympic National Park. Three rescuers were killed in the crash. The rest survived due to heroic efforts of rescuers on the ground.
- In 1998, an AirMed helicopter crashed in the mountains outside Salt Lake City while evacuating a skier injured in an avalanche. Four people died in the crash, including the injured skier.

- In 2002, multiple rescuers were injured when their Pavehawk helicopter crashed and rolled 1,100 feet down Mt. Hood during an attempt to rescue an injured climber
- In 2009, a New Mexico State Police helicopter pilot and his search subject died when the helicopter crashed into a mountainside after the pilot rescued the lost hiker.
- In 2012, two rescuers died during helicopter rescue operations, and a third was injured when struck in the head by a main rotor blade.



A helicopter is only as good as the pilot flying it. Photo: Veteran Flight for Life Colorado Pilot and Helicopter Safety Manager Pat Mahany (by Charley Shimanski)

crash than from a fixed wing crash. Rotary wing aircraft have higher survival rates because the forward speed they must maintain in order to avoid stall is less than a fixed wing aircraft. Thus, when they are about to flare on landing, rotary wing craft have less forward momentum and thus need less room to negotiate a landing (and are less likely to crash into trees and other hazards).

What usually kills people in crashes is not the impact with the ground (unless of course the craft is in a stall), but rather the forward momentum they have when they are landing. In addition, many helicopter fatalities result from fire in the aircraft after the crash rather than from trauma received in the crash itself.

Whether or not any of these accidents were the result of pilot error, it must be noted that a helicopter is only as good as the pilot flying it. Conversely, the pilot of a helicopter is only as good as the machine that s/he is flying. The three major killers of helicopter pilots are “Wind, Weather and Wires.”

Despite these tragedies, the fact is that of all forms of transportation, the number of fatalities due to helicopter accidents is the lowest - just 0.1 percent of the 56,000 transportation fatalities that occurred in 1979. In fact, you may have a far greater chance of surviving a rotary wing aircraft

Part 1 – Helicopter Basics

Use of Helicopters

Today, search and rescue agencies that use helicopters have at their disposal a multi-use aircraft that is capable of performing a variety of missions, including but not limited to the following:

- Search for or attraction of a search subject
- Evacuation of injured parties (either victims or rescue personnel)
- Transportation or extrication of field members
- Heli-Rappel to the site of a victim
- Aerial survey of topography for mission leadership

While fixed-wing aircraft are generally used for searching large open areas, such as above timberline, for obvious clues (e.g. ski tracks, tents, downed aircraft, etc.), helicopters can be used to search areas more difficult to spot from fixed-wing aircraft, such as cliffs, gullies, cliff bottoms, etc.

In search operations, helicopters can also be used as an attraction device. The noise from a helicopter may attract the victim of a search who, in turn, may attempt to attract the attention of those on board the helicopter. In addition, helicopters can be used to transport searchers and/or equipment to remote search and rescue assignments.

Helicopters are often used in rescue situations, whereby an injured subject can be evacuated and transported to a local hospital. There are a number of methods that are used by rescue teams in evacuating injured subjects. These methods include what is referred to as “external loads,” including the use of hoist systems and

slings. Helicopters can also be used to assist in logistical support by transporting rescuers and/or their gear. This can be especially helpful in reducing time spent and fatigue levels of rescuers.

The key to the safe utilization of helicopter resources in any search or rescue operation is for the Incident Commander and other leadership to perform a thorough subjective risk-benefit analysis. Is it worth the risk, for example, to have a helicopter called to evacuate a healthy search subject, simply to avoid the need for a two- or three-mile walkout?



Rescue leadership must perform a thorough risk-benefit analysis in order to assure safe utilization of helicopter resources. Photo: Riverside Mountain Rescue Unit.

Conversely, who can question the need for an air ambulance when the victim of a plane crash is lying unconscious and bleeding profusely at the scene of the crash? Somewhere between these two examples lies the more difficult decision with regard to helicopter utilization.

Helicopter Limitations

Opportunities for helicopter use during emergency operations must be weighed heavily against the risks involved. Search and Rescue teams must be aware of the limitations of helicopters when calling for these expensive resources. Conditions such as altitude, weather and terrain will all affect the usefulness of helicopters in search and rescue operations. All aircraft are limited in their working altitude (called service ceiling), which can change based on the temperature and humidity.

Visibility Minimums

Smaller helicopters generally do not have "Instrument Flight Rules" (IFR) capability, and must fly under "Visual Flight Rules" (VFR).

VFR for helicopters is different from VFR for fixed wing aircraft due to the difference in slowest possible speed of forward flight. Generally speaking, VFR for helicopters means flight conditions "clear of clouds and at an airspeed that enables the pilot to see and avoid collision."

VFR rules dictate that there must be a minimum one-half mile visibility and a 500-foot ceiling (distance between ground and bottom of lowest clouds). For National Guard helicopters, the visibility for VFR is increased to 1 mile. A pilot flying under VFR must have sight of the ground at all times.

During night flying, VFR dictates that there must be a minimum three-mile visibility. It further dictates that there must be a 500-foot minimum below clouds, a 1000-foot minimum above clouds, and a 2,000-foot horizontal distance from clouds.

Instrument Flight Rules (IFR) are those that apply to aircraft with special navigational

instruments that give the pilot greater capability in otherwise difficult flying conditions. IFR allows for flying in conditions where electronics provide the pilot with information not available through the naked eye.

Larger helicopters, such as most of those used in search and rescue operations, either have or are capable of instrument flight capability and can fly under instrument flight rules.

Weather Conditions

Turbulence may be a serious problem to a pilot; therefore mornings are usually the best time for flights because there is less turbulence than with afternoon heating by the sun. Cumulus clouds indicate turbulence and strong updrafts and downdrafts. Also, there are often downdrafts over the middle of a valley, and such currents may be dangerous at high elevations because of reduced engine power. Conversely, updrafts often exist over ridges or on the sunny side of ridges. Leeward side of ridges may have severe downdrafts.

Even if a helicopter is on its way to evacuate a victim, ground personnel should still be dispatched to the scene with the equipment necessary to transport the victim, in the event of a helicopter malfunction, changes in weather or other unexpected complications. Never assume a helicopter en route will become a helicopter on scene.

Fuel

As noted in the "Helicopter Types" section later in this document, each type of helicopter has a limited range due to a limited fuel supply, especially since they are generally based some distance from the typical mountain search and rescue mission. In the case of extended search missions, a mobile fuel tanker might be considered at the heliport to refuel the helicopters. Otherwise, the helicopters will have to leave

the scene to refuel, causing valuable time and a loss of an important resource.

Mechanical

It goes without saying that a helicopter is a machine, and machines do not always work.

This is why a thorough risk-benefit analysis must be performed prior to each and every helicopter operation.

Classifications of Helicopters

Med-Evac Helicopters

Most search and rescue teams will have access to local Med-Evac helicopters, since many rescue missions occur within proximity of a large town with a Class I trauma center. Flight nurses specially qualified in critical care and medicine usually accompany each flight. A physician may be present on flights where the need is indicated, although this is uncommon. These ships can usually carry anywhere from two to four supine adult patients, depending on the type of craft and the internal configuration.

Emergency medical equipment including electrocardiograph monitor, oxygen, defibrillator, suction apparatus, endotracheal intubation equipment, intravenous fluids, transport Isolettes and emergency drugs are all carried on board the helicopter. In effect, the emergency room is carried to the patient for immediate treatment and care.

These air ambulance services provide for the immediate response by an emergency medical team going to the patient via aircraft, starting intensive therapy at the site of the illness or injury and, once stabilized, the patient is then returned as rapidly as possible to the appropriate hospital.

Whenever a med-evac helicopter responds to a mission, search and rescue team members should refrain from talking to the flight nurse or pilot. The only person who should discuss the patient with the flight nurse is the primary medical team member, who will give the flight nurse a full (and brief) update of the patient's condition, nature of injuries, etc. (For further information on this briefing, contact your team's Medical Director. If you do not have a Medical Director, contact the med-evac helicopter's medical director). The helipad director or person most familiar with helicopter operations should be the only person to speak with the pilot while the ship is on the ground.



Flight nurses and/or paramedics are a key element of med-evac helicopters.
Photo: Charley Shimanski

SAR team members should be aware of how med-evac helicopters are dispatched. In most cases, this will be via the local Sheriff's dispatch, although some SAR teams may be able to request these helicopters directly.

In any event, these specially equipped helicopters should be put on stand-by before rescuers are on-scene, if the description of the rescue indicates that an med-evac helicopter may be necessary. By doing so, the pilot and flight crew can familiarize themselves with the terrain and weather conditions before they are actually called on a "chopper go."

Med-evac helicopters also have certain limitations. They are often limited in landing areas by either the regulations or their equipment. If they are working under FAA Part 135, they may be restricted where they can land, particularly at night, as compared to the public use aircraft. Also, their size or configuration, set up mostly for helipads and streets, might not work well in the mountains.

Law Enforcement Helicopters

Many local county Sheriffs or city Police Departments operate helicopters for law enforcement, especially those in the vicinity of a large city. Some of these may be of little or no value in the mountains, due to their altitude limitations, but may be used frequently for search and rescue operations in the foothills. SAR teams should know the limitations of local law enforcement helicopters and their pilots. If either is not capable of flying at altitudes, they should not be considered a resource when high altitude missions are required.

On the other hand, many county governments have sophisticated aviation programs. In most of California, for example, the vast majority of search and rescue operations are conducted by county aviation units. In Los Angeles County, it can be either the Sheriff or the fire department's rescue-equipped helicopters. In other counties it may be a combined unit or a Sheriff's unit. Within the last couple of years, the California Highway Patrol has greatly expanded their program and they are flying missions when county resources are not available, including in mountainous terrain.

Civilian Helicopters

Charter helicopters may be available to SAR teams. These may be a valuable resource to the SAR team, although they usually must charge for their services, therefore a pre-plan should be made with the local sheriff

and the private agency itself. In some situations, funds may be available for search or rescue activities when the need arises. The SAR team leadership should investigate possible sources of such funding before the actual need arises. The SAR team leadership must also be aware of the ships' and pilots' limitations when high altitude flying is required.

Media Helicopters

Search and Rescue teams in close proximity to large cities with network television stations may be fortunate to have at their disposal one or more media helicopters. In many situations, these helicopters can become an extremely valuable resource. Key to the successful implementation of media helicopters is a strong mutual relationship between the SAR team and the local television or radio station that operates the ship. Since these helicopters are an expensive tool for the station, the SAR team must be judicious in requesting these resources.



Key to the successful utilization of media helicopters is a strong mutual relationship between the SAR team and the local television or radio station that operates the ship. Photo: Charley Shimanski

Search and Rescue overhead teams should keep in mind that the media helicopter pilot

and crew have **two** important objectives. The first objective is to "bring home the news story." The second objective is to assist in the SAR mission. The overhead team must respect the media's needs while focusing on its own objectives.

Let's look at what may appear to the SAR team to be insignificant but is, in fact, an important example. Imagine that a television news helicopter, with a SAR member on board as a spotter, is responsible for a "find" during a search operation in which a safe field landing and extrication of the victim is possible. Often, the television station will have a ground crew at the command post, shooting footage of the return of the helicopter. For this reason, the SAR member should allow the pilot to come to full rotor stop and escort the victim off the helicopter himself or herself. The result is good PR for the television station, and appropriate recognition of the contribution of their helicopter, even if the SAR spotter was actually responsible for locating the subject from the helicopter. Remember that it is the television station that foots the bill for the expensive helicopter! And it is the skills of the pilot that enabled the "find."

As with charter helicopters, SAR team leadership must also be aware of the media ships' and pilots' limitations. Nonetheless, these extremely valuable resources should never be overlooked.

Some states have limited private helicopter resources. While California rescue teams still see the occasional military resource, media and civilian helicopters are almost never utilized.

Military Helicopters

Because the armed services have a budget for assistance in civilian search and rescue efforts, SAR teams are increasingly involved in missions involving military helicopters stationed at local Army or Air Force bases.

There are generally three types of helicopters that are available; the double rotor Chinook and the single rotor UH-70 Lakota and Blackhawk. The UH-70 Lakotas are used less frequently for mountain activities due to their altitude limitations.



Requests for Army air support are made through the AFRCC headquarters at Tyndall Air Force Base in Florida. Photo: Scott Darsney

Requests for Army air support are made through the Air Force Rescue Coordination Center (AFRCC) headquarters. Since missions requiring this type of air support are generally multi-agency missions, these requests are most always made by the local sheriff's office or the State Mission Coordinator for the state SAR agency, if one exists.

National Guard resources may also be requested through the state's National Guard Joint Operations Centers.

While military helicopters are often operated by some of the best pilots in the country, they frequently fly under different environments. This may include the radio frequencies available, the types of maps used and the required crew size to fly a mission.

Part 2 – What Makes a Helicopter Fly (Besides Money)

Aerodynamics

Most helicopters operate with a single main rotor and a single tail rotor. If these helicopters had only the main rotor, the fuselage of the ship would spin uncontrollably in the opposite direction of the rotor, due to the torque induced by the main rotor. For this reason, a tail rotor is used to counteract the effect of this torque. In addition, twin rotor helicopters achieve anti-torque by having the two rotors turn in opposite directions.

The actual "lift" in a helicopter is accomplished by the main rotor blade, which has a cross-section similar to the wing of an airplane. As this "wing" moves through the air, spinning on an engine-driven shaft, lift is generated. The amount of lift generated is dependent on the "pitch" or angle of attack of the rotor blade through the air.

If you extend your hand out the window of a speeding car and move the angle of your hand up from the horizontal position, you can feel the lift produced as the angle is increased. A rotor blade works in the same way.

Helicopter Design

The main rotor is the rotor that rotates on the horizontal plane. The main rotor turns at speeds of approximately 300 RPM. Conversely, the tail rotor is the smaller rotor in the rear of non-tandem rotor helicopters, which rotates on the vertical plane. The tail rotor generally turns between 1,500 - 1,800 RPM, making it impossible to see while in motion, **especially at night!** The cabin is

defined as the internal portion of the helicopter where pilots and passengers are seated.

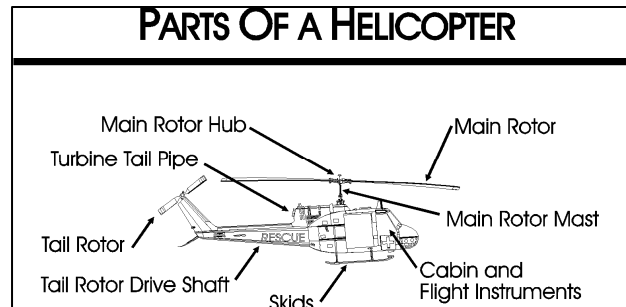

Rotor Systems

There are two basic helicopter designs, the single main rotor helicopter or the dual (a.k.a. tandem) main rotor helicopter. The most common design uses a single main rotor, which imparts lift and thrust, and a smaller tail rotor, which compensates for torque induced by the powered turning of the main rotor.

Some helicopters have dual main rotors, mounted in tandem, side-by-side or one above the other. Torque compensation is achieved by having the two rotors turn in opposite directions.

Helicopter Controls

There are four controls that are used in conjunction with each other when flying a helicopter.

- Collective Pitch Control
- Throttle Control
- Anti-Torque Pedals
- Cyclic

Collective Pitch Control

The "collective pitch control" lever is located to the left of the pilot and moves in a simple up and down motion (remember that in many helicopters, the pilot sits in the right hand seat... what would be the passenger seat of an automobile.). The collective

allows the pilot to vary the angle of attack, or "pitch," of the main rotor blades, increasing the corresponding lift. For turbine engine helicopters, as the collective pitch control is pulled up, the angle of attack of the main rotor blade is increased. As the pitch of the main rotor blades is increased, power must be increased to assure a constant r.p.m. A fuel governor accomplishes this by providing more fuel to the engine as the pitch is increased.

Throttle Control

A handgrip throttle is mounted on the collective pitch stick for coordinated use on piston engine helicopters. The throttle increases or decreases the rate of revolution of the main rotor blade. As the pitch is increased, power must be added to maintain rotor RPM when the helicopter lifts off or climbs. On turbine-powered helicopters, this power coordination is accomplished automatically through the fuel control and governor systems of the turbine engine.

Anti-torque Control

The two floor pedals provide "anti-torque" control by varying the amount of thrust in the opposite direction of the helicopter's main rotor. These pedals control the tail rotor. This anti-torque control is essential because it prevents the helicopter from spinning out of control. By maintaining tail rotor thrust equal to main rotor torque, the helicopter will hold a hover without spinning in any direction. While in a hover, the anti-torque control will allow the pilot to change the heading in any direction.

Two anti-torque pedals counteract torque effect by providing a means of changing pitch (angle of attack) of the tail rotor blade(s). As a result, pedal action will provide heading and directional control in hover and at low airspeeds. The amount of torque varies with changes in power.

On dual rotor helicopters, the problem of torque control is solved through the

counter-rotation of the main rotor blades, thereby accomplishing heading and directional control in a hover. With forward movement, the pilot must blend pedal action with his/her other control movements to produce a coordinated flight.

So what does all this mean? In some situations such as out of ground effect hover (to be explained later), maximum performance, or certain wind conditions, the maximum thrust provided by the tail rotor is unable to counteract torque generated by the main rotor and an uncontrollable turn results. What started as a capability has now become a limitation.

Cyclic Control

The final primary flight control is the "cyclic" control stick, which is controlled by the pilot's right hand via a lever that projects between the legs. The cyclic pitch control produces changes in pitch to each rotor blade individually. If the pilot pushes the cyclic stick forward, the pitch of each blade is increased as it sweeps toward the tail of the helicopter. As each blade swings forward, toward the nose of the helicopter, pitch is flattened. The result is that each blade produces more lift as it swings to the rear than when it swings ahead. Lift-thrust force is produced in the rear, which elevates the tail of the helicopter.

Directional movement of the helicopter (including bank during turns) and speed in forward flight are achieved by use of the "Cyclic Control." The main rotor system is tilted in the direction of the stick movement.

This principle occurs whenever the cyclic is moved, allowing the pilot lateral and roll control of the helicopter.

To hover and move to the left, pitch is changed to each blade, producing more thrust as it swings to the right. A side ward force is produced, pushing the helicopter in that direction. To move to the right, the

rotor blades are unbalanced and more thrust is produced over the left side of the helicopter.

Types of Landing Gear

Several types of landing gear are found on helicopters. Each type of landing gear provides a specialized functionality to the ship. The most common types of landing gear are detailed below:

Retractable Landing Gear

Some of the more refined helicopters are equipped with landing gear that may be retracted during flight. The helicopter, therefore, becomes more aerodynamic.

Skids

Skids are the most common type of landing gear used in light- and medium-class helicopters. Skids are permanent, non-retractable horizontal "feet" which provide a long, flat touchdown surface for the helicopter. Tundra pads and snow pads may be used for weight distribution when landings are required in areas where helicopter weight may cause the ship to settle on landing.

Wheels

Wheels are primarily used on medium- and heavy-class helicopters. Helicopters with wheels may be capable of movement on the ground when, for example, repositioning at a heliport is necessary.

Floats

Floats can be used on land as well as water. There are two types of floats, "fixed" and "inflated."

Part 3 – Principles of Flight

Certain terms are commonly used in reference to the principles of helicopter operations. Familiarity with these terms is important to personnel involved in heliport operations.

Ground Effect

Ground effect is a condition of improved performance encountered when operating near the ground. It is due to interference between the airflow pattern of the rotor system and the ground. The interference is more pronounced the closer the helicopter is to the landing surface.

In Ground Effect (IGE)

Two technical issues must be discussed which effect the performance of helicopters. "In Ground Effect" (IGE) is the effect on the performance of a helicopter by the return of the rotor wash from the ground. As the helicopter's main rotor turns, it creates a cushion of air beneath the hovering helicopter furnishing additional lift caused by the air that is compressed beneath the helicopter. Once the helicopter is above the ground by a distance equal to the diameter of the main rotor, IGE is usually reduced to nothing.

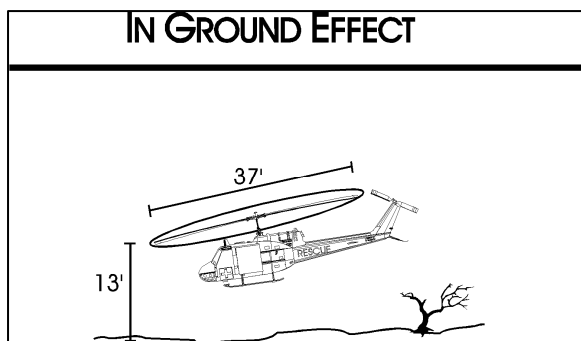

In Ground Effect (IGE) occurs to its greatest extent approximately one-half of the rotor

diameter above the ground. The ground alters the airflow pattern around and through the rotor system. With IGE, the airflow velocity through the rotor system is reduced, as is the drag associated with that velocity. Further, rotor tip vortex generation is reduced. Thus, the lift needed to sustain a hover can be produced with less power.

Out of Ground Effect (OGE)

Conversely, "Out of Ground Effect" (OGE) occurs when the rotor wash is not affected by the proximity to the ground. In other words, OGE usually occurs when the helicopter is more than one-half of the rotor diameter above the ground. In OGE, a helicopter is power dependent when a hover is maintained. This can occur near the ground as well, as occurs when the helicopter is hovering over tall grass, water, and certain types of rough terrain. If the pilot is instructed to try to land in these conditions, the helispot should be described as an "OGE Helispot."

It stands to reason, therefore, that some helicopters can lift less of a payload by sling than they can when the payload is on board the helicopter. The reason is that lift by sling occurs while in OGE.

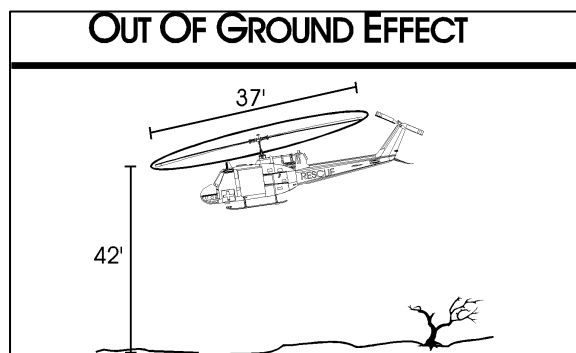

Translational Lift

The efficiency of the hovering rotor is improved with each knot of airflow gained by horizontal movement of the surface wind. As increasing velocities of airflow

enter the rotor system, turbulence and vortices are left behind and airflow becomes horizontal. This improved rotor efficiency resulting from directional flight is called "translational lift."

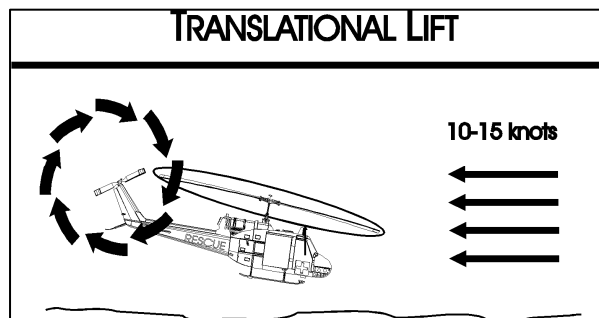

In effect, this is the lift that is obtained from translation from a hover to forward flight. It is felt as a "shudder" in the aircraft.

Effective Translational Lift

At airspeeds between 10 and 15 knots, depending on the model of helicopter, the rotor completely outruns the recirculation of old vortices and begins to work on clean air. Effective translational lift results.

Normal Takeoff

Normal takeoff is the procedure used where flight of the helicopter is not limited by the presence of obstructions---natural or man-made. The normal takeoff procedure is made into the wind to obtain maximum airspeed with minimum ground speed.

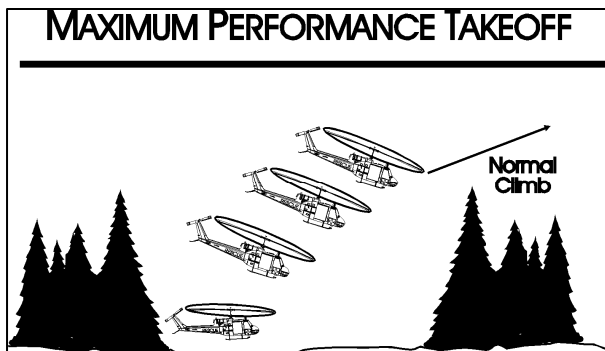
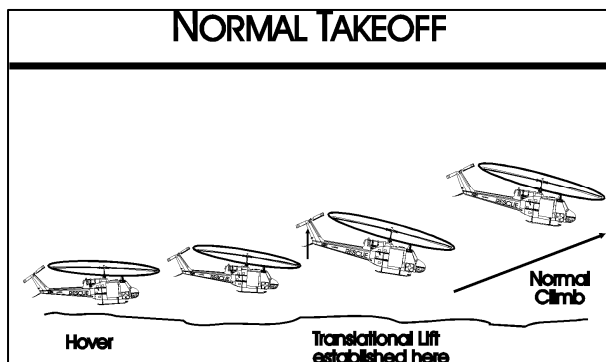

Maximum Performance Takeoff

"Maximum performance takeoff" is the takeoff procedure used when departing a confined area, that is, where flight of the helicopter is limited by terrain or other obstructions. During the maximum performance takeoff, little use can be made of ground effect or translational lift until the obstruction has been cleared. Thus, the rotor system is less efficient and greater demands are placed on the power plant, with less remaining power left as a safety margin. This explains why hover holes and confined helispots should be avoided, whenever possible. Remember that the greatest strain on a helicopter's engine occurs during landings and takeoffs, and hover holes and confined helispots leave little room for error.

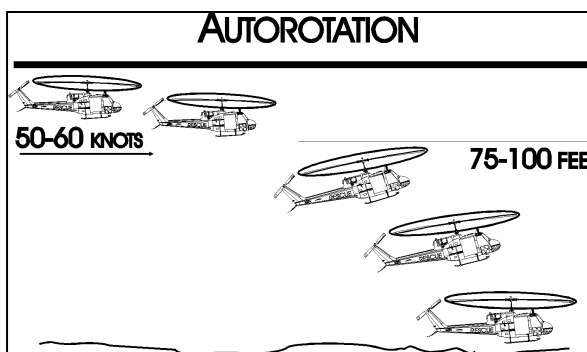

Autorotation

"Autorotation" is the term used for the flight condition during which no engine power is

supplied to the rotor system and sustained flight is possible from the rotor blades. The pilot can use the inertia for collective pitch to slow the rate of descent and effect a safe landing. Unlike fixed wing aircraft, rotor wing aircraft are capable of controlled landings during most conditions when power is lost; assuming a suitable landing surface exists below the helicopter. Helicopter pilots often train in autorotation landings.

Part 4 – Helicopter Management and Safety Precautions

Safety training of rescue team ground personnel must include items requiring special care in and around helicopters, either on the ground or in the air.

Prior to each day's operation, a briefing should be conducted. This briefing should set forth the plan of operations for the pilots and the ground personnel, covering such items as on-the-ground and in-the-air safety precautions. Pertinent safety plans and flight hazard maps should be reviewed before the flight is scheduled. Remember that the pilot is responsible for the safety of the helicopter at all times. The pilot should, therefore, be encouraged to participate in the planning so as to assure safe utilization of the helicopter at all times.

Operation of the helicopter should be during daylight hours whenever possible (defined as ½ hour before sunrise to ½ hour after sunset). The mission's leadership must be aware of wind velocity and visibility and, subsequently, not dispatch helicopters for mountainous flying when the average wind velocity exceeds the different helicopters' limitations.

Passengers of the helicopter should request a briefing from the pilot prior to the flight to ascertain the location of emergency exits, fire extinguishers, emergency electrical and fuel shut-off, emergency locator transmitter (ELT) manual switch, first aid kits and survival gear. No unauthorized personnel should be allowed to fly on any mission.

Helicopter hand signals should be used whenever possible, but only by personnel trained in such activities. Finally, all

personnel should stay at least 100 feet away from helicopters, except when loading.

Landing Zones (“LZs”)

Contrary to popular belief, helicopters do not normally land "on a dime," but rather require or desire a sizable landing zone, particularly at high elevation. Helicopters generally will not take off or land vertically. Rather, they need a landing zone (often called an "LZ", referred to throughout this material as a "helispot") that may be hundreds of feet long. The ideal helispot is a flat strip 100 feet wide and 300 feet long (roughly the size of a football field). Flat ridges and saddles may provide the best helispots in the field. Highways, streets or roads unobstructed by outlying trees are suitable as well, but in this case traffic and crowd control must be available by law enforcement authorities.



The ideal helispot is a flat strip 100 feet wide and 300 feet long (roughly the size of a football field). Photo: Dave Bathke

A primary reason helicopters need large landing zones is that a helicopter with engine failure (more common upon takeoff due to high engine stress) needs extra room to land safely.

Remember that "Out of Ground Effect" (OGE) occurs when the rotor wash is not affected by the proximity to the ground. In OGE, a helicopter is power dependent when a hover is maintained. When considering landing zones, remember that OGE can occur near the ground as well, as occurs when the helicopter is hovering over tall grass, water, and certain types of rough terrain. If the pilot is instructed to try to land in these conditions, the helispot should be described as an "OGE Helispot."

In ground effect explains why some helicopters can lift less payload by sling than they can on board.

Helispots should be designed in such a way that the helicopter can land and take off into the wind to increase lift. Only as a last resort, a "hover hole" helispot can be chosen. This is a landing zone where, due to size restrictions, the pilot must slow to a hover above the landing area and then descend to the ground. When taking off, the pilot must use all available engine power, which leaves no room for error. The dangers are obvious; therefore "hover holes" should be avoided at all costs.



Helispots should be defined in such a way that the helicopter can land and take off into the wind to increase lift. Photo: Howard Paul

Since the typical helicopter can kick up rotor wash in excess of 100 mph on takeoffs and landings (significantly more on Chinooks), the helispot should be free of lightweight objects that will blow away. Tall dry grass and shrubs should be avoided to prevent possible damage to the sensitive tail rotor. Tree stumps should be less than 1 foot high. A snowfield can make a good helispot, but markers such as backpacks must be placed near the helispot to give the pilot some sense of depth perception.

Night operations are becoming more common with the availability of instrument flight rules. Since night landings and takeoffs are significantly more dangerous, SAR team leaders must consider the risks vs. benefits of performing night operations. If this is absolutely necessary, the pilot must be advised of optimal flight paths to avoid hazards such as trees, peaks, ridges and especially power lines. At night, the helispot may be marked by rescuers' headlamps held on and aimed steady without wavering.

If the helispot is near any vehicles, two vehicles with headlights on, located 40 yards downwind and at opposing 45-degree angles to the proposed helispot, may illuminate the helispot. The helicopter will then approach between the two vehicles and will land near the intersection of their lights, roughly 40 yards upwind from the vehicles. These vehicles should have **low** beams on so as not to blind the pilot or flood the instrument panel with light.

In the event that the pilot cannot locate the proposed helispot, due to other surface lights in the area, emergency vehicle lights can be illuminated. As the helicopter approaches, put out all lights except those used to illuminate hazards and the touchdown pad. All strobes and rotating beacons must be shut off as well, as this can cause vertigo and affect the pilot's horizon.

Air-to-Ground and Ground-to-Air Radio Traffic

The Incident Command Post or Air Operations Branch Director may or may not have direct radio communications with helicopters involved in a search or rescue. TV, private, media and med-evac helicopters may or may not be equipped with the local/state SAR or EMS channel. Army helicopters (Chinooks, UH-70 Lakotas and Blackhawks) may not be equipped with programmable radios and may be required to use specialized aviation frequencies or other common emergency frequencies such as National Law Enforcement Channel (NLEC) at 155.475 Mhz or Fire Emergency Radio Network (FERN) at 154.280 Mhz.

Field teams should avoid ground-to-air radio communication unless they have something very important to communicate. Even though field teams will likely hear air-to-ground radio traffic, including inquiries from the helicopter crew, they will likely have a harder time receiving the traffic from the ground.

On board non-military helicopters, either the pilot or the spotter can communicate over specific radio channels, as dictated by the pilot. As mentioned earlier, the spotter should minimize unnecessary communication with the pilot, since the pilot must monitor additional radio traffic that the spotter may not hear on his/her headset. Generally, the pilot will give the spotter specific instructions on how to communicate with the Incident Command Post or ground personnel using the ship's radio.

If a helicopter is used for searching, and does not have the local/state SAR or EMS channel on its radio, the spotter can use a handheld radio on board. Such communications will generally be poor,

however, due to magnetic and audible noise that affects both transmission and reception. Using a headset connected to the handheld radio in place of the normal speaker and microphone can alleviate some problems.



Rescuers should minimize radio communication with the pilot, since the pilot must monitor additional radio traffic that the spotter may not hear on his/her headset. Photo: Charley Shimanski

As mentioned earlier the spotter can usually communicate using the helicopter's intercom, although the spotter should avoid unnecessary communication with the pilot, since the pilot will often monitor air-to-ground traffic that the spotter may not hear.

In the aircraft itself, rescuers should understand the concept of a "sterile cockpit." This procedure was developed in flight crew management studies done for the military and air carriers. It mandates no conversation on the aircraft intercom radio during departures and arrivals until a safe altitude is reached. That allows the crew to focus solely on clearing the airspace and communicating with ATC.

Landings and Takeoffs

Landings and takeoffs are generally made easier in the presence of a light, steady breeze (such as 10 knots or 12 mph) than in still air. In addition, the pilot may choose not to take off or land in a wind greater than 45 knots (approximately 50 mph) or with a gust spread of over 20 knots (23 mph).

When landing, a pilot will often make a high level pass over the helispot for observation of obstacles and wind indicators and then will come in on a "final approach" (a.k.a. "final"). Despite the tendency to watch during this approach, all personnel not in the helispot should look away to avoid injury by flying debris kicked up by the rotor wash, especially with Chinooks. All ground troops must hold down any loose gear.

During final approach, only one ground person should be in the helispot. This person is referred to as the "parking tender." With the helicopter some distance away, the touchdown point is indicated by the parking tender standing upwind with his/her back to the wind and his/her arms facing toward the desired landing spot.

During landings on snow, no rescuers should be in the landing zone at any time. There is always the chance that the helicopter's weight will cause it to settle in the snow, which could be dangerous for any rescuer in the helispot. A similar, nearly fatal accident occurred on Mount Robson, Canada, in 1981.

Parking Tenders

To a helicopter pilot, the parking tender may be the most critical person in the field. This guide, designated by the field site commander, should be the person most familiar with helicopter operations, including landing zones, ground-to-air communications and helicopter safety.

Once the helicopter is within radio range, the parking tender should make radio contact with the pilot. Knowing that a knowledgeable parking tender is available will ease the mind of most pilots flying into mountainous terrain. As the ship enters the area of the rescue, the parking tender's communication with the pilot becomes essential.



Knowing that a knowledgeable parking tender is available will ease the mind of most pilots flying into mountainous terrain. Photo: Christiane Leitinger

Ground-to-Air communication during landings and take-offs

Radio communication from rescuers on the ground to the helicopter pilot and/or crew is essential for rescuers to safely land a helicopter at a proposed landing zone. Any pilot on an incoming ship will want to know the precise location of the proposed landing zone. The location should be clearly specified, using landmarks such as roads. Pilots generally do not carry the usual 7.5' USGS quadrangle maps used by ground search teams.

The helispot should also be clearly defined. This may be an empty parking lot near the Incident Command Post. More likely, it may be in the mountains and the general nature of the terrain should be stated. Its elevation should be stated as well as any

obstructions, including distance and bearing (e.g. "100 foot tower 300 feet SSE of helispot"). Aerial wires **must** be mentioned, as these are often unmarked and very difficult for a pilot to see (The 1988 KUSA helicopter crash that killed pilot Galanis and photographer Hostetler was the result of unmarked power lines. Today, those same lines have "floaters" on them.). Wind indicators and obstacles must also be pointed out as the ship approaches.

Most all pilots may require longitudinal/latitudinal coordinates when attempting to find a helispot. Any team member proficient in reading topographic maps should be able to provide this information (CAUTION: DO NOT confuse longitude/latitude coordinates with UTM's or the helicopter may end up in Bolivia!).

Once the parking tender has the helicopter in sight, it should be easy to direct the pilot to the proposed helispot. This is done using the clock method. Imagine the helicopter mounted on the base plate of a clock. The helicopter's nose points to twelve o'clock, its tail to six o'clock. Using this orientation, you can easily guide a pilot to your location by telling him or her, for example, "The helispot is at **your** 2 o'clock." Combining this orientation with an estimated distance from the ship to the helispot will greatly assist the pilot.

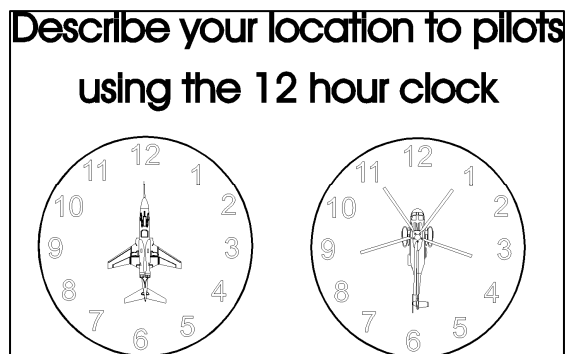

Finally, weather conditions must be described. The "ceiling" is the distance from the ground to the lowest clouds, and should be stated in feet. "Visibility" is stated in miles. Temperature is very important, as is an estimate of wind velocity, direction and gust spread ("gust spread is the spread between the lightest gust of wind and the heaviest, e.g. 10-25 mph). Parking tenders should make note of this information while the helicopter is en route and read from their notes to the helicopter pilot as s/he approaches.

Under the difficulty of mountain operations, providing indication of wind direction and velocity to pilots is one of the most valuable tasks that the parking tender can perform. While some groups use small film-canister size smoke grenades, many do not. Most teams avoid using smoke grenades of any kind because of the extreme fire danger involved. The heli-spot manager's observations and trail tape streamers are just as effective and a lot safer. Streamers or plastic flagging in bright colors may be tied to rocks, bushes, trees or poles.

If smoke grenades must be used, the parking tender should activate them downwind of the helispot, and to one side of the approach pattern, as the helicopter makes its high level pass over the helispot. If wind is light (under 10 mph) and variable, smoke may obscure the helispot and become more of a hindrance than help. Commercial smoke grenades, usually about the size of a film canister, will work for less than a minute, so don't get too anxious when using them. Also, parking tenders should wear gloves when activating them. Most military grenades cannot be hand-held due to the heat they generate.

Wind indicators should be placed as close to the edge of the helispot as is safe, so the pilot gets a true picture of the ground currents at the site. Make certain that streamers or flagging are secured so they are not dumped by the helicopter's rotor wash.

Parking tenders or other rescue team members should establish these wind indicators well in advance of helicopter's arrival.

Keep in mind that wind coming over a ridge can change. Positioning some flagging to the sides of the LZ on the ridge top may provide more valuable information as well.

If no experienced parking tender is available, it is important that some rescue member still establish communication with any incoming helicopter. A pilot will easily be able to ask the right questions of the untrained person to determine the landing conditions. To a pilot, an inexperienced ground contact is much better than no ground contact at all!

Hand Signals

If the pilot is to be given hand signals by a rescuer, the pilot must be told where this person is and what s/he is wearing. The rescuer must be familiar with the standard hand signals or should stay away. This is no time to use arbitrary signals that could be misinterpreted by the pilot. For example, guide a helicopter pilot to a landing zone by waving your arms back and forth and the pilot may avoid you like the plague. You see this signal is the universal "Wave-off" signal that tells the pilot not to land! In a recent SAR mission, field team members who were expecting a helicopter ride back to the Incident Command Post were left in the field because they used the "wave off" to catch the pilot's attention. The pilot **did** see them, and interpreted this as a signal to leave the area, and he did so. The result... a long walk out for the field team. The problem with the "wave off" signal is that it is the instinctive reaction to alert a helicopter of your location. Be careful not to use it unless you are using it appropriately.

When a helicopter is landing at any heliport or helispot, it may be necessary to have a SAR team member acting as helispot

parking tender, guiding the pilot to the helispot with hand signals. These hand signals are as follows. First, as the helicopter makes its high level pass and as it begins its final approach, the helispot parking tender stands at the end of the helispot, with his or her back to the wind. The arms are extended towards the landing area, which means "Land here, facing me, my back is to the wind." Then, as the helicopter approaches the helispot, the parking tender extends his or her arms outward with clenched fists, which means, "Hold your hover."



The "Wave-off" signal tells a pilot **NOT** to land due to hazards. Photo: Charley Shimanski

As the helicopter skids or wheels get within several feet of the ground, the arms are slowly swept downward, indicating "move downward." As the helicopter skids or wheels touch the ground, the parking tender should hold the arms extended outward at a 45 degree angle to the ground with the thumbs pointing downward. This says to the pilot "Hold your helicopter on the ground. Then, if the helicopter is to come to full rotor stop the parking tender crosses the neck with the right palm facing down (a.k.a. "kill it"). This means "Shut down your engine(s)."

If the parking tender is confident that the pilot is on final approach to the desired helispot, there may be no reason to continue to stand in the middle of the helispot and get blasted by the rotor wash. The parking tender may wish to alert the pilot that s/he will move away from the helispot as it approaches.

Rest assured that a pilot might often choose to ignore a rescuer giving hand signals. It is not because the pilot him/herself is not familiar with them. Rather, a cautious pilot may be uncertain as to whether or not the rescuer is indeed familiar with the signals, and may not trust the rescuer. After all, pilots are not mind readers and they have every right to trust themselves more than a stranger. Furthermore, the pilot may be more aware of weather conditions such as wind gusts and visible terrain and may choose his or her own angle of approach. Nonetheless, a simple understanding of these signals is valuable and should be known by any search and rescue team member that may work around helicopters.

Attached to this document are examples of helicopter hand signals.

Safety Precautions on the Ground

Several important precautions must be clearly understood by all ground personnel. It is important that rescue teams train their personnel in these basic safety operations:

Ground personnel should **never** run when approaching or leaving a helicopter. Furthermore, they should always approach and leave the helicopter with head and equipment low, but maintain eye contact with the pilot when doing so. Approaches should be made in a crouched position from the front or side of the helicopter and in full view of the pilot (except with Chinooks).

A helicopter should never be approached from the side where the ground is higher

than where the helicopter is standing or hovering.

Any rescue passenger of a helicopter must observe safety guidelines when flying in commercial light helicopters. First, they should wear a helmet at all times when near or on board the helicopter. Fire-resistant clothing and leather boots should be worn, if at all possible.



Rescuers should always approach and leave the helicopter with head and equipment low. Photo: Todd Rector.

For Department of Interior (United States Forest Service, National Park Service and Bureau of Land Management) contracted helicopters, rescuers **MUST** have NOMEX, all leather boots, and an approved helmet.

Rescue members should carry a portable two-way radio capable of transmission on air-to-ground and ground-to-ground frequencies at a minimum. If at all possible, rescuers should wear the radio in a chest harness to allow easy access, although the radio should be turned off to avoid feedback on the on-board radio headsets. Rescuers should also carry a backpack. In military helicopters, the pilot may request the backpack be stowed in a cargo bay. Whenever a rescuer is going to offload in a one-skid or hover jump situation, however, this equipment should be stored securely

between the legs with all loose equipment secured. (An errant water bottle caused a helicopter at Sequoia-Kings National Park to make an unscheduled emergency landing in 1998).

The pilot must be advised if any explosive, flammable or otherwise dangerous materials are to be carried on board. This includes any firearms.

In-flight Precautions

While helicopters are in flight, rescue personnel on board the helicopter must make several precautions.

First, the pilot's word is final as to whether or not the flight can be made.

Before takeoff, all passengers must fasten and adjust the safety belt and shoulder harness. After landing, they should keep this equipment fastened until instructed to leave the helicopter. The passenger should refasten this equipment on the seat and assure that no belts are outside the helicopter as the door is closed.

Passengers must locate the emergency exits and review instructions. There should be **NO SMOKING** during takeoffs or landings. Even at the pilot's discretion, rescue personnel will **NOT** smoke during the flight.

Rescuers must keep clear of all controls and must hold maps and papers securely while in flight. They must also keep geographically oriented at all times. They should assist the pilot by keeping alert for hazards, particularly other aircraft and power/telephone lines. They must inform the pilot of their presence and, when requested to do so, assist the pilot in watching tail rotor's clearance during landings at field LZ's.

Occasionally, helicopters will be used with the doors removed or left in the open

position. In these circumstances, make sure nothing can accidentally fly out of the helicopter. If necessary, put away all maps, notebooks, and secure everything loose. It doesn't take much to damage a tail rotor.

Do not throw objects out of the helicopter at any time, except when instructed by the pilot to do so. In this case, communication with the pilot is essential so as not to disrupt the balance of the helicopter. Do not move about the helicopter while in flight.

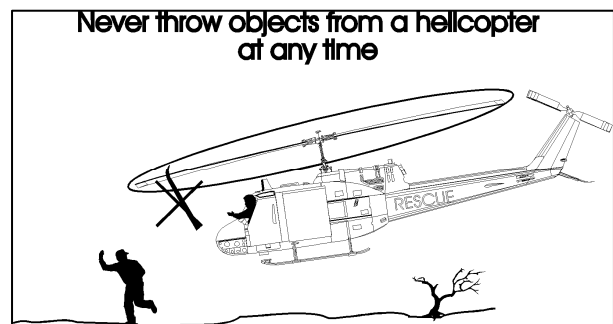

With the assistance of the pilot, maintain radio communication with the heliport and/or the command post at all times.

One-wheel or one-skid landings should not be performed without the approval of the Heliport Manager, Operations Chief and/or the Incident Commander.

Loading and Unloading

Approaching the Helicopter

Before approaching any helicopter, make sure the pilot has got the ship down on the helispot the way s/he wants it. Often, the pilot will need to jockey the ship around a bit before s/he feels comfortable enough to ease the power off, a noticeable change in engine pitch. The universal "thumbs up" sign might be given by the pilot to indicate s/he is ready for you to approach. If the

pilot is not ready, s/he will let you know in a hurry!

When approaching, all equipment such as packs, skis, snowshoes, and ice axes must be carried horizontally below waist level, never upright or over the shoulder. Skis are especially dangerous, since mountaineers generally carry them upright, over one shoulder. Avoid this practice when approaching a helicopter, unless you like **reeeeeeeeally** short skis.



With the exception of Chinooks, you should approach the helicopter only at an angle visible to the pilot. There is no reason, **ever**, to go back past the skids or the side doors. If you must change sides, do so by going around the front of the ship, where you and the pilot can always see each other. As you approach the ship, squat in a low profile to maximize head to rotor clearance. Don't look down though; **always** look at the pilot. Depending on the helispot and other flight factors, s/he may have to hold a bit of power on. If so, the helicopter may pull off suddenly due to precarious positioning, or if it goes into ground resonance (the helicopter begins to vibrate due to harmonic imbalance between landing gear and rotor blades). In either of these cases, the helicopter **must** become airborne.

If it becomes necessary that a rescuer approach the helicopter without first being signaled to do so, that person should stand directly in front of the ship and wait until

s/he has the attention of the pilot or crew chief. S/he should then point directly at the ship, an indication that the rescuer wishes to approach the helicopter. The pilot or crew chief will generally signal the rescuer to approach (This DOES NOT apply to Chinooks! At no time should a rescuer approach a Chinook from the front!).

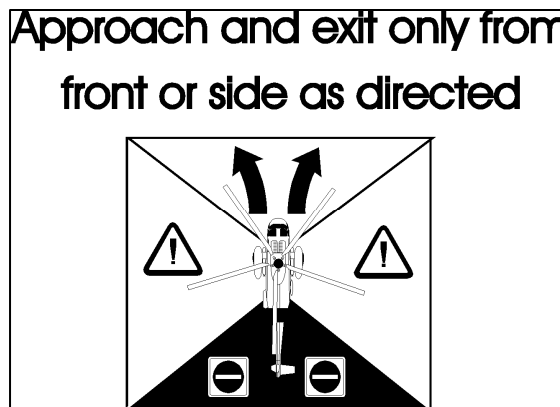

If the helicopter is going to cool down to full rotor stop and the pilot plans to leave the ship to discuss the mission with the Incident Commander, Operations Chief and/or field team leaders, no rescuer should approach the ship until the rotors have come to a FULL STOP. Plan on at least two minutes per engine to cool down.

There should be no smoking within 200 feet of the helicopter during landing, loading or takeoff procedures. There must be **NO SMOKING** while aboard ANY aircraft at ANY time.

Loading and Unloading Safety Procedures

Each of the loading and unloading guidelines listed below assume that the helicopter must maintain rotor power, increasing the hazards exponentially.

All loading or unloading must take place on the downhill side of the ship, since the rotor blade may be as close as 5 feet to the ground in many models, even when the ship is on level ground.

For all but the Chinook, loading should be from within 60 degrees of the front to be visible by the pilot.

At all times, the tail rotor must be avoided. This rotor is not visible while turning at high speed. Several cases of decapitation have resulted from careless passengers. The pilot must see all personnel within reach of the tail rotor so that s/he will not turn the tail around in that direction.

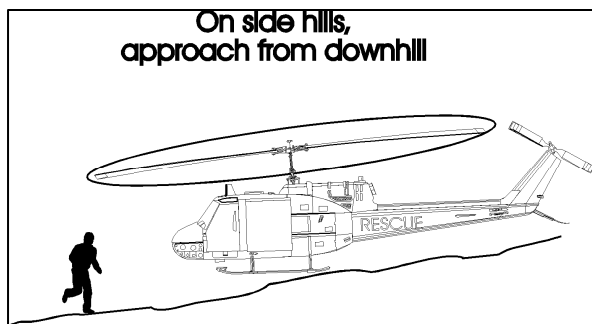

Every rescuer on board a helicopter should wear "Personal Protective Equipment (PPE)." PPE includes a helmet with the chinstrap securely fastened. Eye protection, such as shatterproof glasses, is important as well, and ear protection is critical. Finally, fire-resistant clothing such as NOMEX suits should be considered, although this is often not practical for field rescue personnel in mountain rescue operations (As mentioned earlier, for Department of Interior-contracted helicopters, rescuers MUST have NOMEX, all leather boots, and an approved helmet).

As the rescuer approaches the ship, packs should be carried, not worn. Once on board, rescuers should immediately fasten their seat belt and secure their equipment.

Of course it is highly unlikely that you will be involved in a crash while aboard a helicopter. Still, if your pack is small enough and can be safely secured between your feet (instead of stowing the pack in the

luggage compartments), you may want to keep it within reach when loading the helicopter. This way, you have your survival gear and, hopefully, a hand-held radio nearby in the case of a crippling crash.

Unloading the helicopter requires the same general safety procedures as loading. To reiterate, all personnel will exit downhill toward the front of the ship (except with Chinooks)...NEVER towards the tail. The head should be kept low and rescuers should leave the helicopter only when specifically told to do so. Prior to exiting, rescuers should refasten their seat belts underneath them so that the belt cannot fall outside and bang against the fuselage while in flight.

One-Skid Landings

Generally, a helicopter will be fully on the ground when rescuers enter or exit. There may be conditions, however, when the pilot is only able to put one skid down and may actually be in a semi-hover while rescuers exit the ship. This situation is called "one-skidding."



For one-skid or hover boarding and exiting operations, extra caution must be used, and a few signals and procedures discussed beforehand with the pilot. Photo courtesy Flight for Life Colorado

"One-skid" landings occur when one skid or one wheel of a helicopter is placed on the

ground and the helicopter retains high rotor RPM's to keep level in the air. For one-skid or hover boarding and exiting operations, extra caution must be used, and a few signals and procedures discussed beforehand with the pilot.

Helicopters are very sensitive to weight and balance. Stepping in or out of a helicopter balancing on one skid should be done very **e-a-s-i-l-y** to avoid radical weight change on one side of the ship. The probability of a downdraft, power settling, or recirculation effect occurring is high during a hover or one-skid. In the case of one-skid unloading, communication between the pilot and rescuer(s) is essential. The pilot needs time to adjust his/her controls for the increased or decreased load coming onto or off of one side of his helicopter. The last thing the pilot wants is for a clumsy, adrenaline-loaded 200-lb. rescuer to jump anxiously from the ship.

To exit a helicopter in a one-skid landing position, you should not open the door of the craft until told to do so by the pilot. Once the door is open, drop your pack out. It is important that you tell the pilot that you are about to do this. Shifting weight in a small helicopter can throw the balance of the ship, and the pilot must be prepared. With your headset still on, tell the pilot "On the count of three, I will drop my pack out...one, two three." After gently dropping the pack out of the helicopter, prepare to exit the ship.

Again, with your headset still on, you should complete all communications with the pilot (It is fruitless to attempt to yell at the pilot without your radio headset). You should tell the pilot "I will step smoothly from the ship after I give you the count of three...do you understand?" The pilot will generally agree or advise otherwise. At this point, upon approval from the pilot, remove your headset. Then remove your seat belt and refasten it behind you, while you stay in the seat. You may then prepare to exit, and give

the pilot the count of three. Once on the ground, you should quickly move away from the ship, towards the front and on the downhill side, so the pilot can leave the area as soon as possible. If you cannot move away, stay as low to the ground as possible.

If there is more than one rescuer off-loading via a one-skid landing, each rescuer should do so one at a time. Communication is especially critical for any rescuers in the back seat of small helicopters, since the pilot may find it impossible to see these rescuers. Once on the ground, the rescuer(s) should quickly move away from the ship, towards the front and on the downhill side, so that the pilot can leave the area as soon as possible. If rescuers cannot move away, they should hold their position and stay crouched as low as possible.

Frequently, the tightness of the landing area where a one-skid takes place is steep and complicated terrain. Do not run uphill onto the rotor blades or scramble out of the way along a rock arête where one slip will mean a long fall. Often it may be impossible to move away from the helicopter. In this case, hold your position and wait for the ship to complete its task and take off. Protect yourself from the usual hazards, which are not readily apparent when a helicopter's engine is screaming full-throttle one meter away from your head on the top of a pinnacle. In any case, let the helicopter maneuver away before continuing with your search or rescue activity.

Try to find or make a place to land, rather than performing one-skid or hover-load routines. An ordinary evacuation of a lost subject or victim with a broken leg can transform into tragedy in an instant if the helicopter goes down for any reason.

Part 5 – Search and Rescue Helicopter Operations

Rescuers aboard Helicopters

Rescuers aboard any helicopter must board the helicopter fully prepared to hike out since flying conditions can quickly deteriorate. In fact, a helicopter may be able to safely land to avoid such weather, yet may be unable to take-off later.

A rescuer aboard a helicopter may find it difficult to follow the course of the ship on a map in unknown territory. For this reason, rescuers should study their topographic map carefully before takeoff, and look for prominent landmarks as soon as the ship is airborne.



Rescuers aboard any helicopter must board the helicopter fully prepared to hike out. Photo: Bill Vargas

When an opportunity arises for a SAR team to put a rescuer on board a helicopter during a mission, the team's leadership should always use rescuers experienced with

helicopter operations and proven to have a stomach strong enough for helicopter flying. Unlike fixed wing flights, helicopter flights may often be akin to a roller coaster ride without the tracks in front. Helicopter flights during SAR missions are no time to reward a SAR team member for his or her efforts in non helicopter-related operations.

Dogs aboard Helicopters:

Search and rescue dogs can be trained to ride in helicopters, although their handlers and other SAR professionals need to be aware of several factors that affect a search dog.

First, dogs have very sensitive ears and they react to vibrations – especially low frequency vibrations. The larger the helicopter, the lower the frequency of vibrations. Dogs can become fearful when approaching or riding in these larger aircraft. Handlers should be prepared to carry the dog on board. Additionally, handlers should make sure the dog has relieved him/herself before the helicopter approaches – or the dog may just do so at that moment.

Some dog handlers will use an Ace-bandage to wrap around the dogs mouth to avoid the dog biting anyone during the stress of the loading and/or ride.

While in flight, the dog handler should talk to the dog, and reassure it that everything is OK. Of course the dog takes its cues from the handler.



Dogs can be trained to ride in helicopters during search and rescue operations. Photo courtesy Flight for Life Colorado

Additionally, SAR dogs may be exposed to fumes from helicopters that could negatively impact their ability as a search dog. The smell of burning aviation fuel can be strong, and disruptive for a dog.

Chinook and other military helicopters generally have some amount of hydraulic fluid on the floors and ramps of the helicopters. This can be an irritant for a dog's paw, especially if the paw is in any way injured or raw.

Nicholas Razum, one of the founders of the search dog unit within the Los Angeles County Sheriff's Department, has developed an informative web site on search dogs and helicopters. (For more, go to <http://www.helitac.net/>).

Searching From Helicopters

Often during search operations, helicopters will be used to try to locate the subject. In

this case, a rescuer, called a "spotter," will fly with the pilot. Obviously, the pilot must devote his/her attention to the helicopter; therefore the spotter is necessary to assist in the searching aspect.

Again, a spotter may find it difficult to follow the course of the ship on a map in unknown territory. Especially in this case, spotters should study their topographic map carefully before takeoff, and look for prominent landmarks as soon as the ship is airborne. Nothing could be worse than finding a search subject in the middle of a rocky outcrop, with no idea of where you are.

If at all possible, the spotter should be an experienced rescuer, familiar with communications to ground personnel, the nature of the search and the overhead team's definition of "probability of area." This person should be experienced with helicopter flying, and should not necessarily rely on the pilot to determine which area is best to search. The spotter should also be someone very familiar with the area of the search, and know where the Incident Commander wants the helicopter resource to be working

The spotter will generally wear a radio headset, provided by the pilot. Using this headset, the pilot and spotter can talk to one another aboard the intercom. In addition, either can communicate over other radio channels, as dictated by the pilot. While aboard the helicopter, the spotter should minimize unnecessary communication with the pilot, since the pilot must monitor additional radio traffic that the spotter may not hear on his/her headset.

Extrication of Subjects by Helicopter

If a subject, injured or otherwise, is extricated by helicopter, special care must be taken. First, the ground personnel must be certain that nobody, including rescuers, approaches anywhere near the tail rotor. This is best accomplished by designating two SAR personnel to stand at the front and rear of the ship while it is on the ground.

Extricating Uninjured Search Subjects

If the subject of a search is located by helicopter, it may be possible to land, pick up the subject and return to the Incident Command Post. Certainly, the rescuer must determine if the potential risk is necessary.



Rescuers should carefully consider the risk of using a helicopter to extricate uninjured subjects. Photo: Phreakdigital.

If the subject is in good physical condition, the rescue team should consider guiding ground teams to the subject, then walking or driving the subject out of the field. Rescuers must remember that most "ordinary" people are not accustomed to being around a helicopter and the hazards,

therefore, become very real. This is no time for heroics when heroics are unnecessary.



Loading of injured subjects will often take place with the rotors turning, increasing the risk to all involved. Photo: Charley Shimanski

When offloading subjects, rescuers should not allow them to leave the helicopter on their own. In many cases, the first thing a person will do is exit the helicopter by walking back towards the tail rotor. Especially in the case of children, it is advised to allow the engine to come to complete rotor-stop before offloading the subject.

Extricating Injured Victims of Rescues or Searches

Often, rescue personnel will assist med-evac helicopter personnel with field loading of injured parties. This may often occur while the rotors are turning; increasing the danger to all involved.

As the rescue team members carry the victim to the helicopter, often in a litter or on a backboard, the SAR personnel should take the lead from the flight nurse or pilot, who will choose the path to the loading door of the helicopter. Once the patient is securely loaded on board the helicopter, rescuers should **immediately** exit the area

by walking directly to the front of the helicopter and beyond it, in the same direction. By doing so, nobody approaches the tail rotor and the pilot has the rescuers in his view at all times.

Emergency Procedures

Unlike fixed wing aircraft, helicopter pilots can often land their ship with a reduced risk of injury, assuming a suitable helispot exists. When power to the main rotor is lost, the pilot will put in negative pitch in the main rotor to initiate a controlled descent at the rate of perhaps 1800 feet per minute. As the ship comes within 75-100 feet of the ground, the pilot will add pitch, checking the descent. The pilot often has only 5 or 10 seconds to land the ship in this process of autorotation. Most pilots actually practice autorotation in training activities.

Once a passenger is on board the helicopter, s/he should check to see that seat belts and equipment are tightly secured. In addition, location of exits, door handles, fire extinguishers, and the Emergency Locator Transmitter (ELT) and its manual switch should be noted before the flight and passengers must stay out of the way of the controls.

During an emergency, it is possible that the pilot may want heavy items dropped out of the ship, if time permits - although this is unlikely. Do nothing else until told to do so by the pilot, including exiting upon landing.

Conclusion

Of all the information listed above, the following are most important:

- THINK! Panic is your worst enemy around helicopters.
- Never approach the helicopter until the pilot gives the OK.
- Always approach or leave the helicopter in the crouched position from near the front (except with Chinooks) so that you are in view of the pilot.
- Never approach or leave a helicopter from any side where the ground is higher than the landing pad - you may walk into the rotor blade.
- Never approach or exit a helicopter with the rotors turning unless instructed by the pilot to do so.
- If you have little or no experience around helicopters, rely on team members who have the necessary experience.
- The pilot in command of any aircraft is directly responsible for, and is the final authority as to the operation of that aircraft.

Jim Frank - Santa Barbara County Sheriff's SAR

Mike Fyola - Pilot, Jefferson County (CO) Aviation Wing and Colorado Army National Guard

Kevin Kelble – Flight Paramedic; Flight for Life Colorado, St. Anthony's Hospital, Denver CO

Peter Peelgrane - Chief Helicopter Pilot, KUSA-TV Denver CO

Mark Reese - Office of Aircraft, U.S. Department of the Interior

Mike Silva - Helicopter Pilot, KCNC-TV Denver CO

Mike Vorachek - Bonneville County (ID) SAR

Rich Westra - Helicopter Pilot, KMGH-TV Denver CO

Acknowledgements

My personal thanks to Tim Kovacs, Past President of the Mountain Rescue Association for his invaluable assistance in development of this program. In addition, thanks to the following individuals and organizations that assisted in the development of this program:

Flight for Life Colorado staff and pilots; Denver CO
Air Life staff and pilots; Denver CO
Drew Davis - Past President,
Mountain Rescue Association